

# muli

PRODUCT INTRODUCTION



## muli Motor eu





The muli Motor eu sets a new benchmark for sustainably produced cargo bikes. The components and add-on parts were selected in an extensive development process focussing on local production. With a few exceptions, this has been successful: 90% of all installed parts are produced within the EU. The muli frame is manufactured entirely in Germany by a network of specialized partners and at the muli Factory in Cologne. The tubes are made from local recycled steel, resulting in a high quality and durable product.

# multi Motor eu: Origin of components

-  GERMANY
-  PORTUGAL, HUNGARY, ITALY
-  NON-EU

30% PARTS  
FROM EU  
(Portugal,  
Hungary, Italy)

60 % PARTS  
PRODUCED IN GERMANY

10% PARTS  
FROM NON-EU  
REGIONS

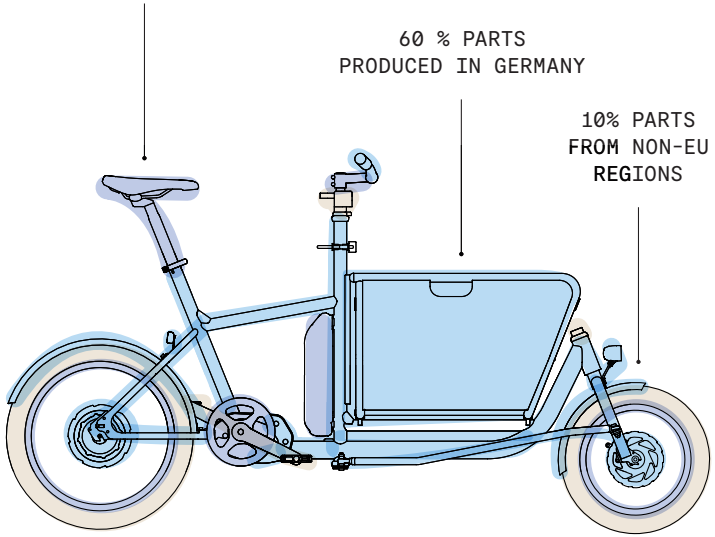

# multi Motor eu: Key facts

---

MADE IN  
THE EU

**90%**

---

POWERFUL  
MOTOR

**Bosch**

---

COMPONENTS  
SELECTION

**as local  
as possible**

---

INNOVATIVE ELECTRICAL  
GEAR HUB

**3x3 NINE**

# multi Motor eu: Origin of components

---

## (A) GERMANY

Frame & Basket  
Rear hub  
Brakes  
Handlebar  
Handlebar grips  
Seat post  
Spacer  
Rim lock  
Fenders  
Lighting  
Bell

---

## (B) PORTUGAL

Stem  
Crank  
Chainring  
Chain

---

## (C) HUNGARY

Motor  
Battery

---

## (D) ITALY

Stand  
Saddle  
Seat clamp  
Front hub

---

## (-) NON EU

Tires  
Inner tubes  
Pedals  
Stem adapter  
Headset



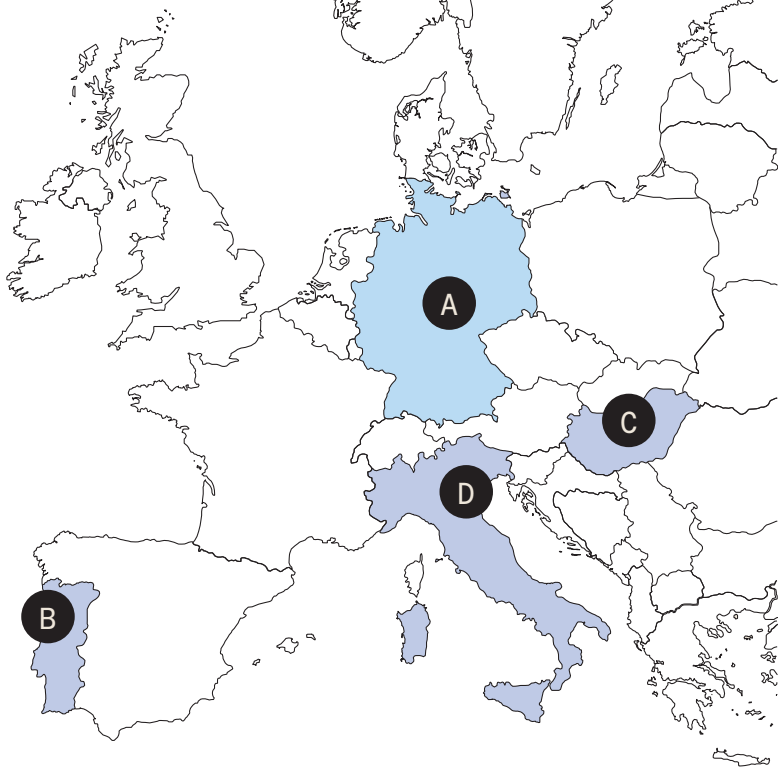

A

B

C

D

# multi Motor eu: Origin of frame

---

## PROCESS

- 00 Sourcing (A)
- 01 Melting (B)
- 02 Tubing (B)
- 03 Lasering (E)
- 04 Welding (B, C, E)
- 05 Cathodic Coating (D)
- 06 Powder Coating (D)
- 07 Assembling (B)
- 08 Packaging (B)

---

## LOCATIONS

- (A) Lower Saxony
- (B) North Rhine Westphalia
- (C) Hessen
- (D) Brandenburg
- (E) Bavaria

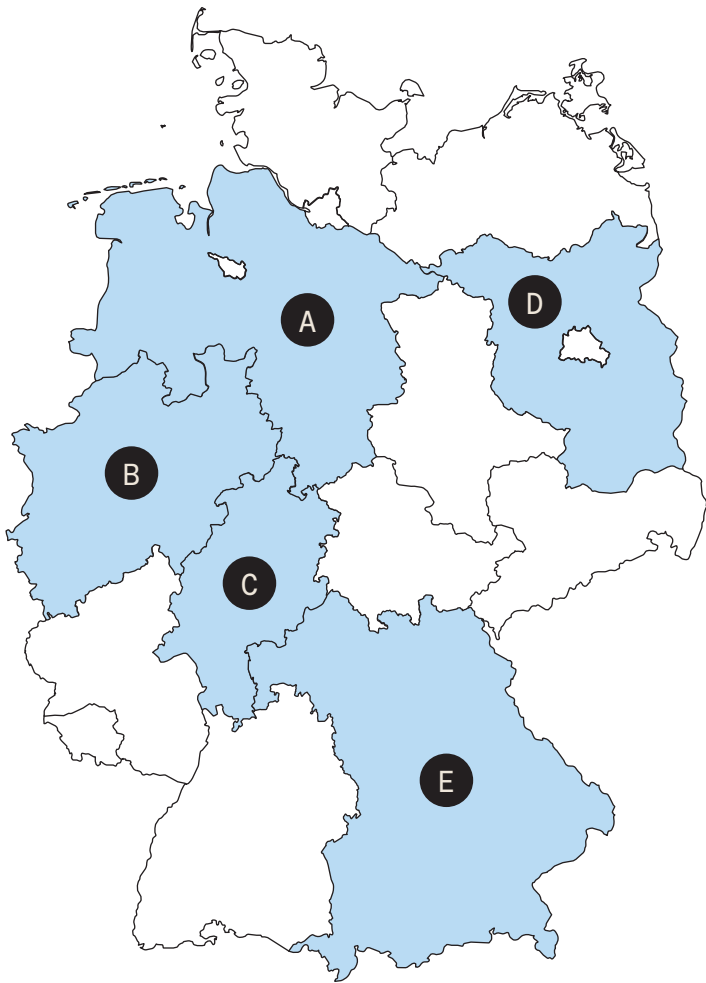

[www.muli-cycles.de](http://www.muli-cycles.de)